

Model ECSA20 - External Double Halyard

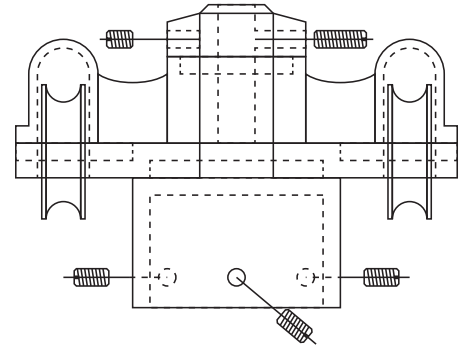
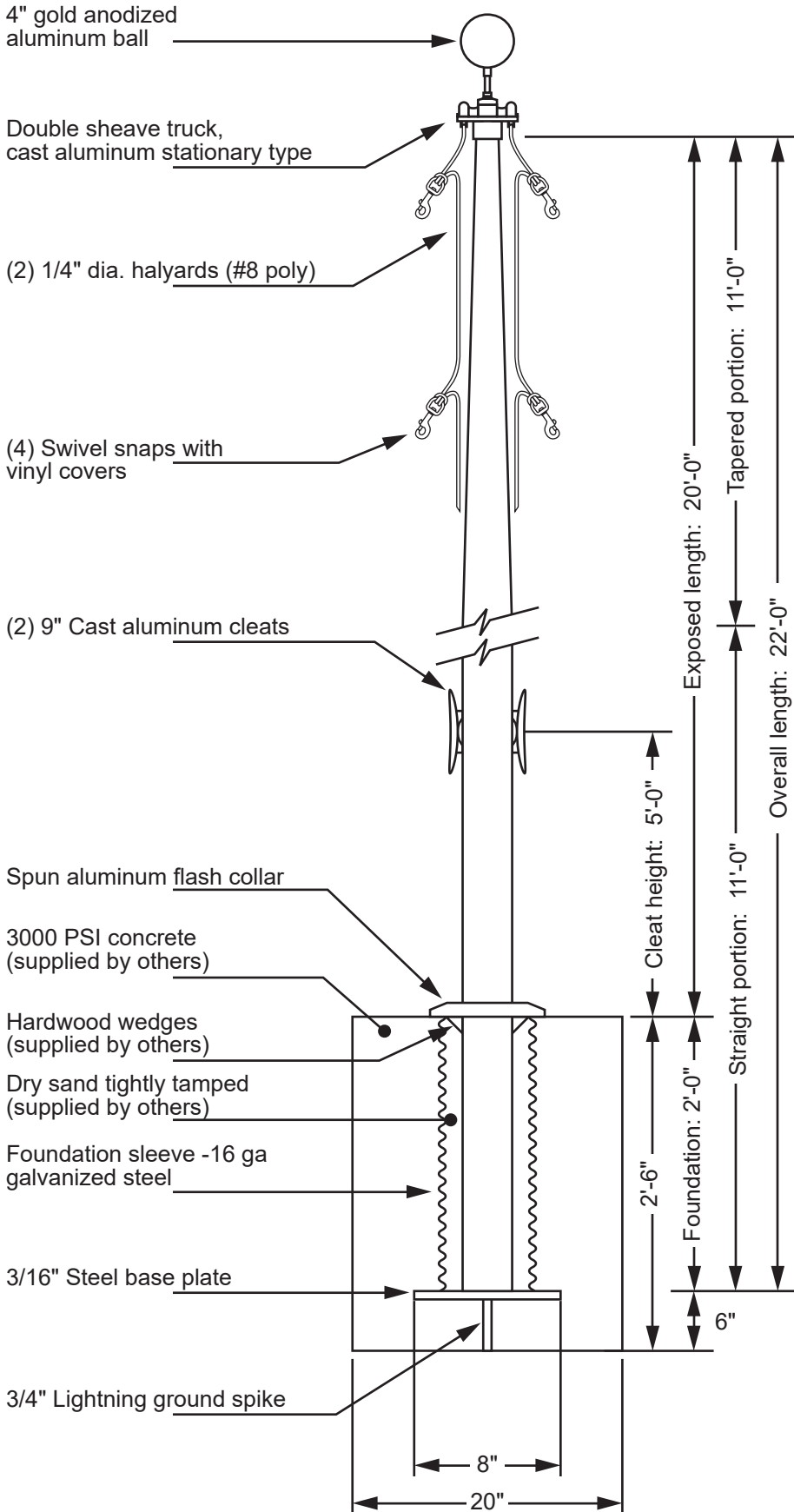

Double Sheave Truck Detail
 Revolving truck
 Cast aluminum body
 Nylon sheaves

Project:
 Location:
 Contractor:
 Customer:

Date:
 Job:
 Revision:

Exposed Height ___ 20'-0"
 Overall Height ___ 22'-0"
 Butt Diameter ___ 4"
 Top Diameter ___ 2-3/8"
 Wall Thickness ___ .125"
 Ships in 1 section

Ground Set Tapered
 Aluminum Flagpole
 ALLOY 6063T6
 80 grit polish

FINISH:

EDER FLAG
 1000 W. Rawson Avenue
 Oak Creek, WI 53154
 www.ederflag.com

