

Model ECH30 - Hurricane External Double Halyard

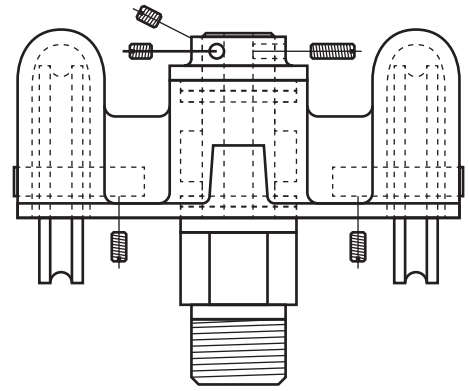
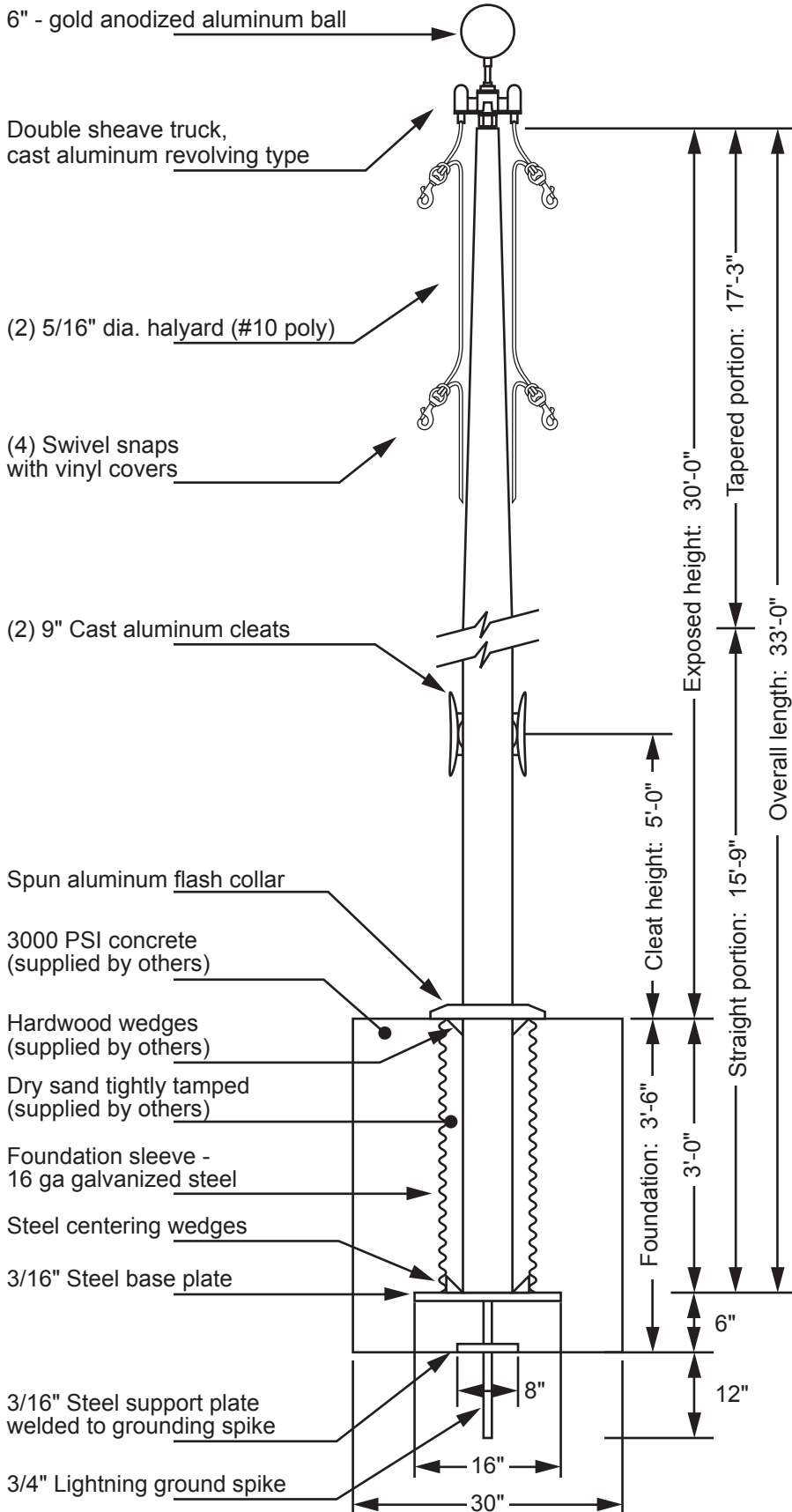

Double Sheave Truck Detail

- Revolving truck
- Cast aluminum Body
- Stainless steel ball bearings
- Nylon sheaves
- Cast aluminum spindle

Each section matched and marked for field assembly. Exposed portion of jam sleeve must be **well lubricated** prior to assembly.

1-1/2" maximum shop gap allowed for field fitting.

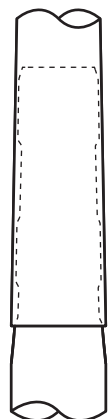

Project:
Location:
Contractor:
Customer:

Date:
Job:
Revision:

Exposed Height __ 30'-0"
Overall Height __ 33'-0"
Butt Diameter __ 6"
Top Diameter __ 3-1/2"
Wall Thickness __ .250"
Ships in 2 sections

Ground Set Tapered Aluminum Flagpole
ALLOY 6063T6
80 grit polish

FINISH:

EDER FLAG
1000 W. Rawson Avenue
Oak Creek, WI 53154
www.ederflag.com

