

Model ECV20 - Vanguard Internal Halyard

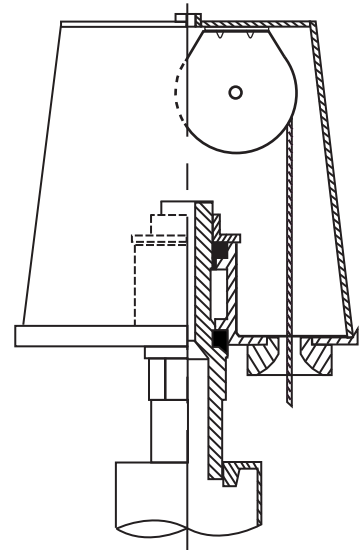

Revolving Internal Halyard Truck
 Cast aluminum body
 Enclosed stainless steel ball bearing and raceway
 Plated steel sheave

Reinforced, cast aluminum access frame mounted to shaft with 8, 1/4 20 x 1/2" stainless steel flat head screws.

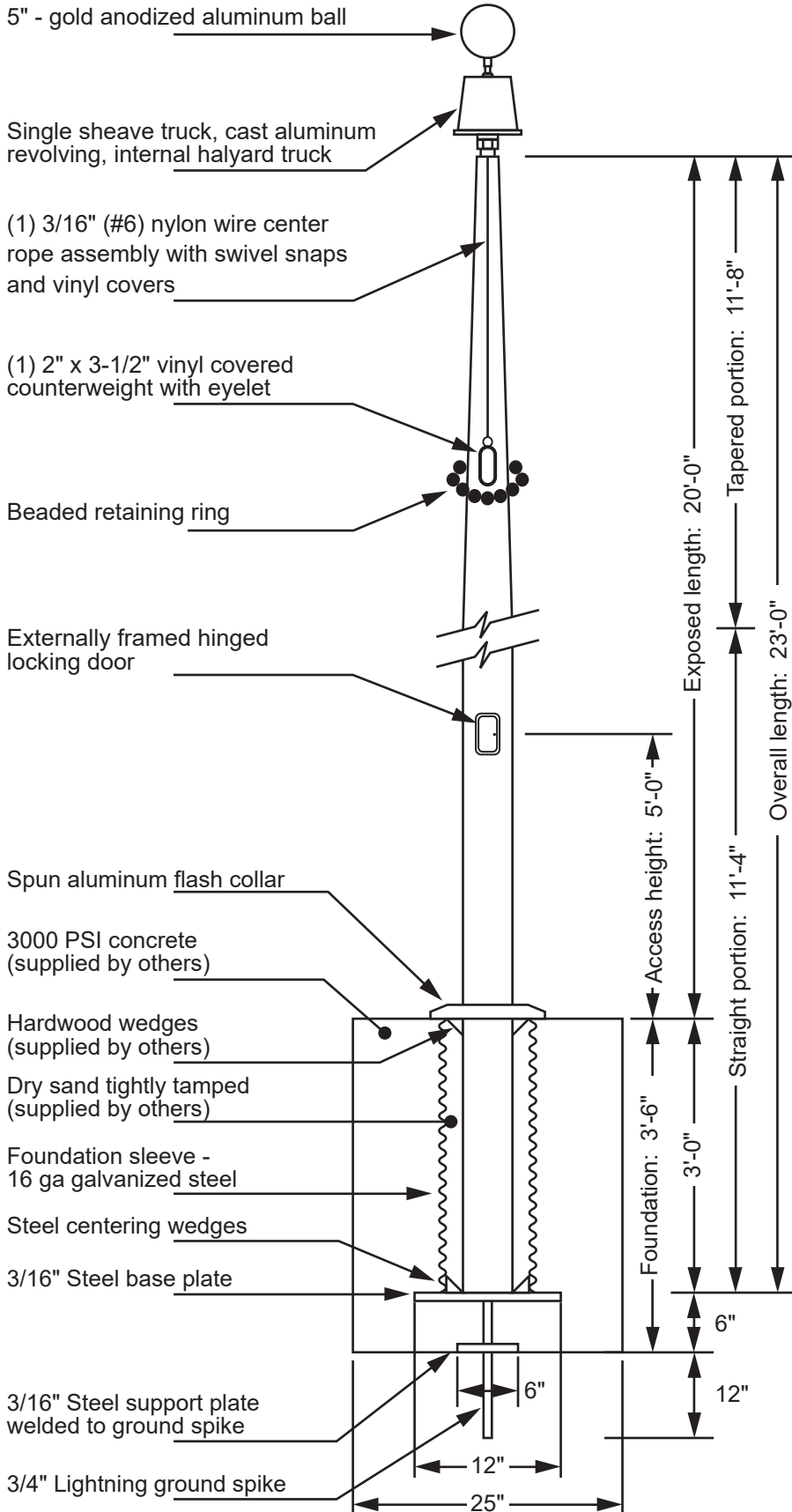
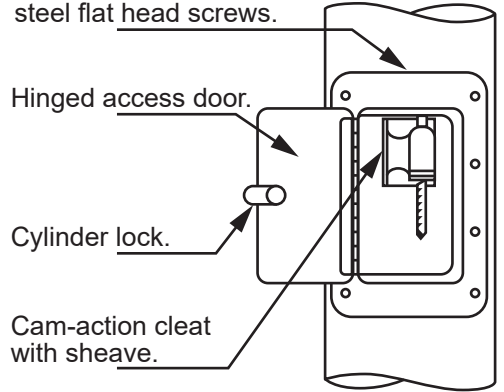

Project:
 Location:
 Contractor:
 Customer:

Date:
 Job:
 Revision:

Exposed Height __ 20'-0"
 Overall Height __ 23'-0"
 Butt Diameter __ 5"
 Top Diameter __ 3"
 Wall Thickness __ .188"
 Ships in 1 section

Ground Set Tapered Aluminum Flagpole
 ALLOY 6063T6
 80 grit polish

FINISH:

EDER FLAG
 1000 W. Rawson Avenue
 Oak Creek, WI 53154
 www.ederflag.com

